

# **Mobilize SalesLogix on BlackBerry with Vaultus**

***Featuring Chad Mercer  
from ING – a Large  
Financial Services Firm***



# Vaultus Mobile Technologies: Background

- Software firm based in Boston. Spin off from M.I.T.
- Mobile software enables firms to run SalesLogix and other applications on BlackBerry® devices.
- What's Unique about our Technology?
  - ✓ Mobile Data Compression Technology (10/1ratio)
    - 100mb of PC data stored in 10mb of device memory
    - 200,000 records on BlackBerry; 400x more than previously possible
  - ✓ Online & Offline Mobile Data Security
    - Lease Key Technology protects SLX data when Radio Signal is OFF
  - ✓ Mobile Application Studio – Makes Customization Effortless
    - Graphical tools for configuring and maintaining SLX on BlackBerry

# Where Vaultus Sits in the Enterprise

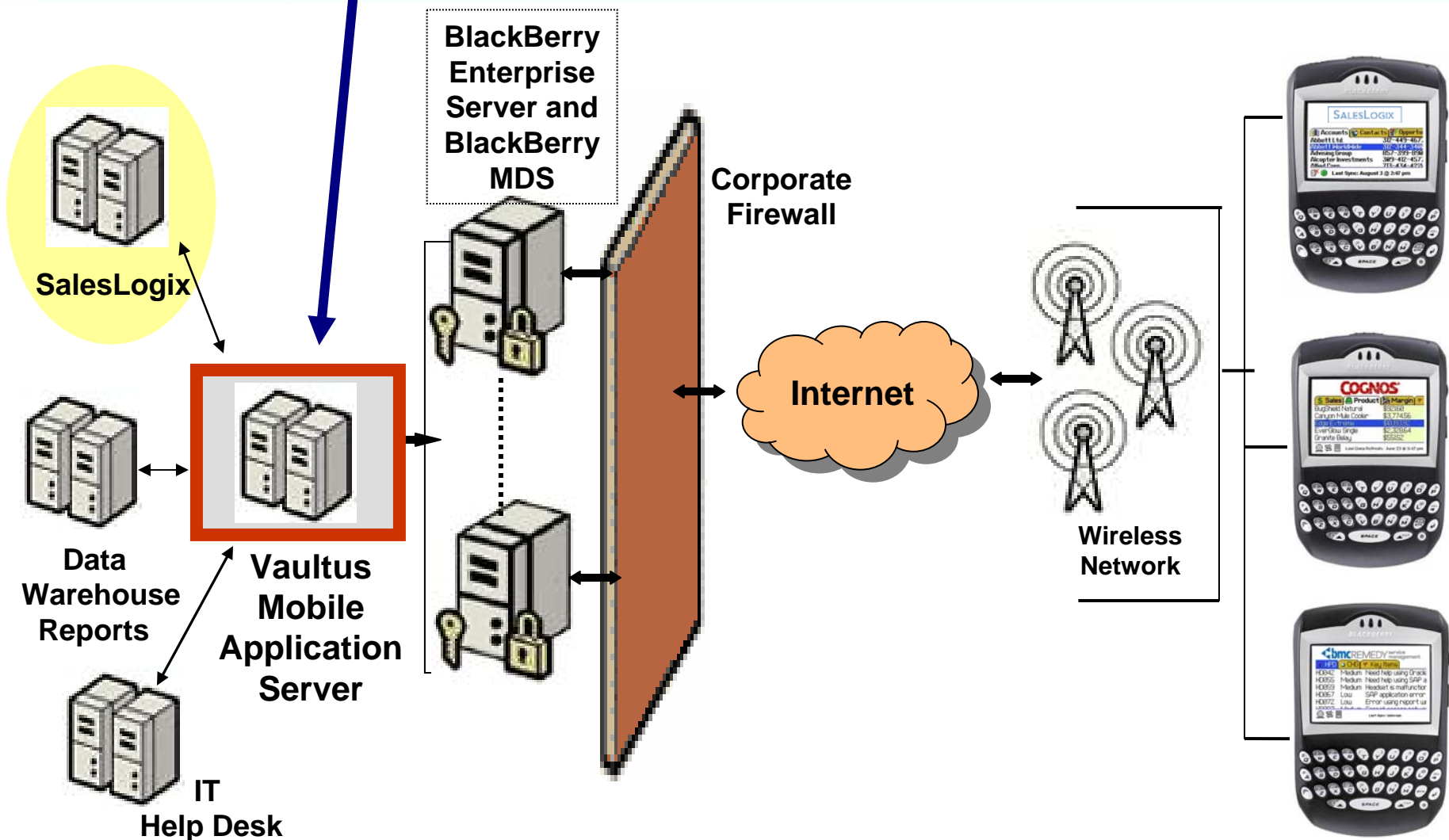

# Just 2-Clicks to All your SalesLogix Data

Fast Navigation via customizable tabs

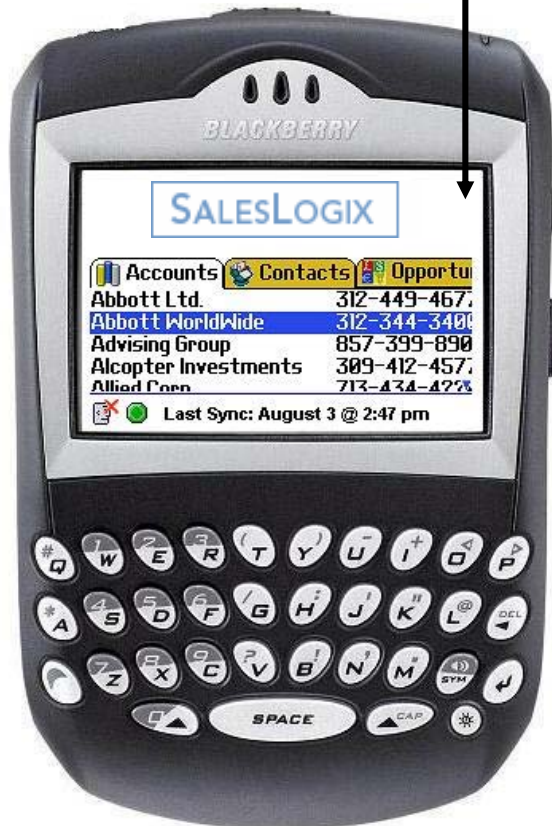

View company/contact info via a single screen

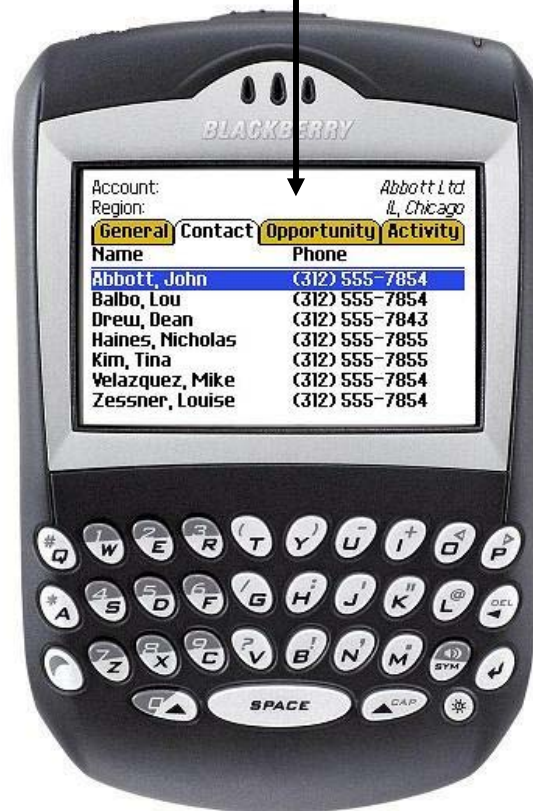

Quickly navigate thru data via BlackBerry trackwheel

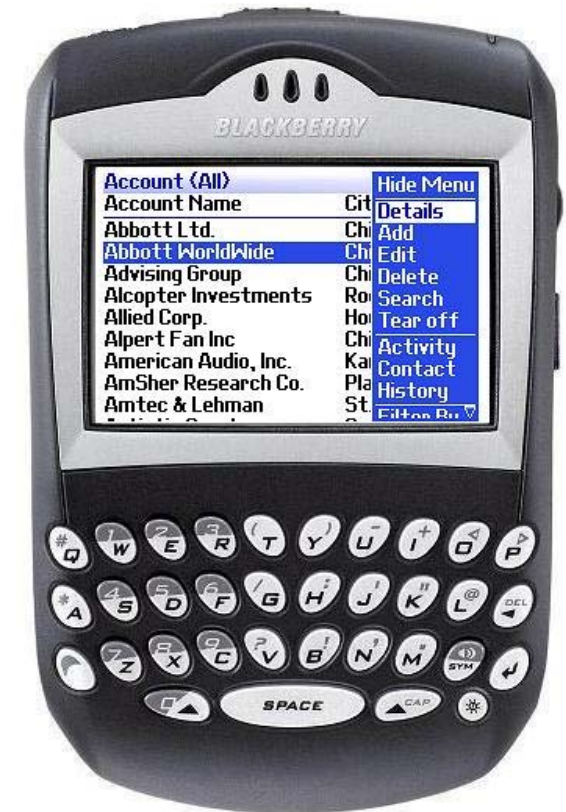

# Reporting Dashboards

Access Your Reports on BlackBerry

Reporting  
Applications

Data  
Warehouses



1. Instant access to sales, product, and organizational performance data in ANY database
2. View performance by day, week, month, quarter and year
3. Quick drill-down from division-region-district-rep.
4. Customizable dashboard views
5. Data refreshed automatically



# Sample Reporting Dashboard Screens

One Hand Navigation via "Tab" Interface



Quickly Drill Down to Specific Data



Generate Your Own Graphs and Charts

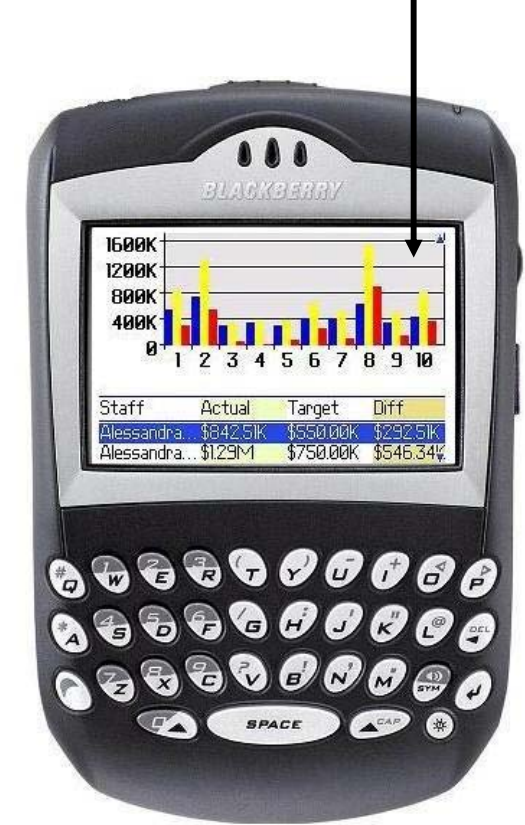

# Vaultus: Vast Experience with SalesLogix

- **5 years experience - specializing on BlackBerry and SalesLogix**
- **“Out-of-the-Box” SalesLogix functionality on BlackBerry**
- **Vaultus has the world’s largest installed base of SalesLogix and BlackBerry customers**
- **40+ SalesLogix customers...and growing**
- **ING will speak shortly – about their experience extending SalesLogix to BlackBerry – and give you helpful advice**

# Sample Screens: Intuitive “Tab-Based” Interface

Fast Navigation via customizable tabs

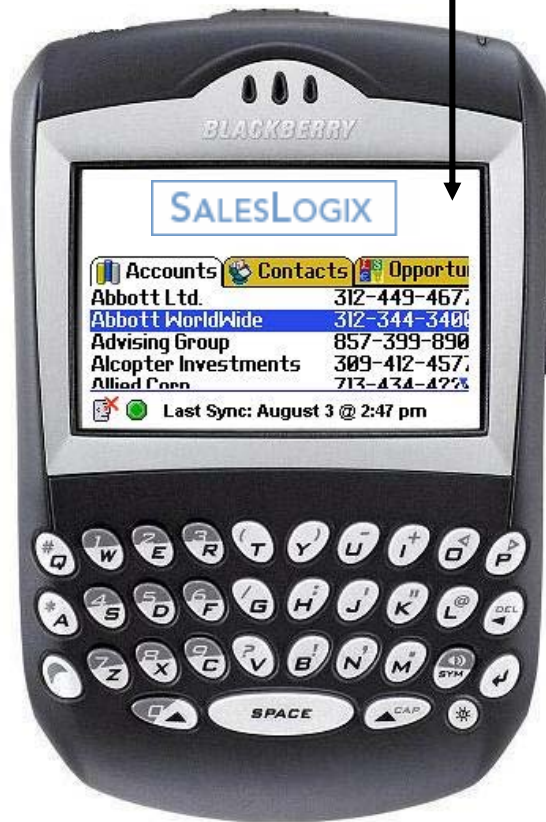

View company/contact info via a single screen

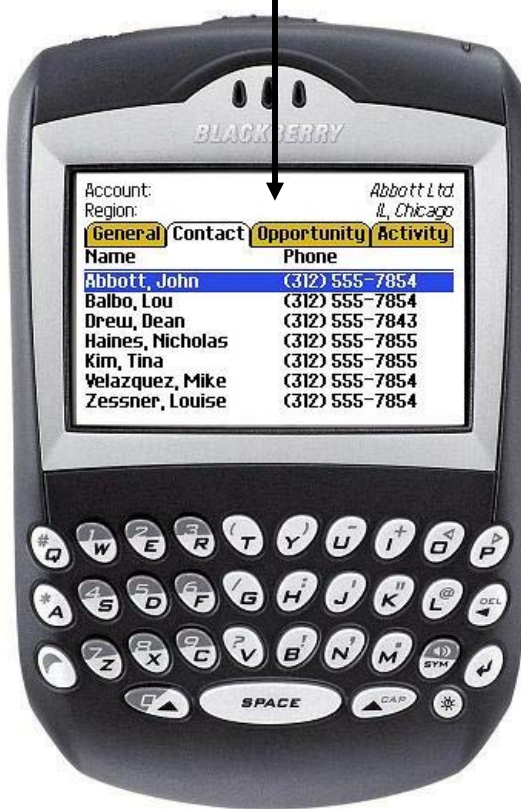

Quickly navigate thru data via BlackBerry trackwheel



# SalesLogix BlackBerry Solution: What's Unique?

- **SalesLogix – and all the data – stored locally on the BlackBerry device**
- **100% “Off-Line” Functionality** – regardless of wireless coverage
- **Tremendous Data Storage.** Reps can store **200,000 records** on the BlackBerry device.
- **Rapid navigation via tab-based interface.** Screens can be quickly tailored to meet user requirements
- **Syncing happens automatically in the background.**
- **Ability to add SalesLogix contacts from BlackBerry address book**
- **Launch calls and email contacts from SalesLogix list views**
- **Emails sent to contacts automatically logged in history record; Incoming emails also get logged in contact history record.**

# ING Case Study.... Chad Mercer

- ING Overview
- How ING uses SalesLogix
- Why ING invested in extending SalesLogix to BlackBerry (i.e. Project Goals)
- What benefits have ING's sales reps realized by being able to access SalesLogix on the BlackBerry device
- Advice for other SalesLogix firms considering similar BlackBerry projects



# Vaultus SalesLogix Solution: In Summary...

- **Rich User Experience and Optimized Productivity**
  - Robust offline SalesLogix application that contains and virtually ALL the data
  - Excellent application responsiveness regardless of wireless coverage
- **Rapid Navigation to Any Data in SalesLogix**
  - 2 – clicks to all SalesLogix data
  - Unique tab interface simplifies use of SalesLogix
- **Low Cost Implementation and Maintenance of SLX Mobile Application**
  - Application Studio cuts configuration and maintenance in 1/2
  - Extensible platform enables reuse of core components across multiple applications
- **Centralized Control of all Mobile Users, Applications, and Data**
  - One management console for SLX and all other mobile applications
  - One security model for all mobile users, applications, data and devices



# Be Up and Running in a Few Weeks...

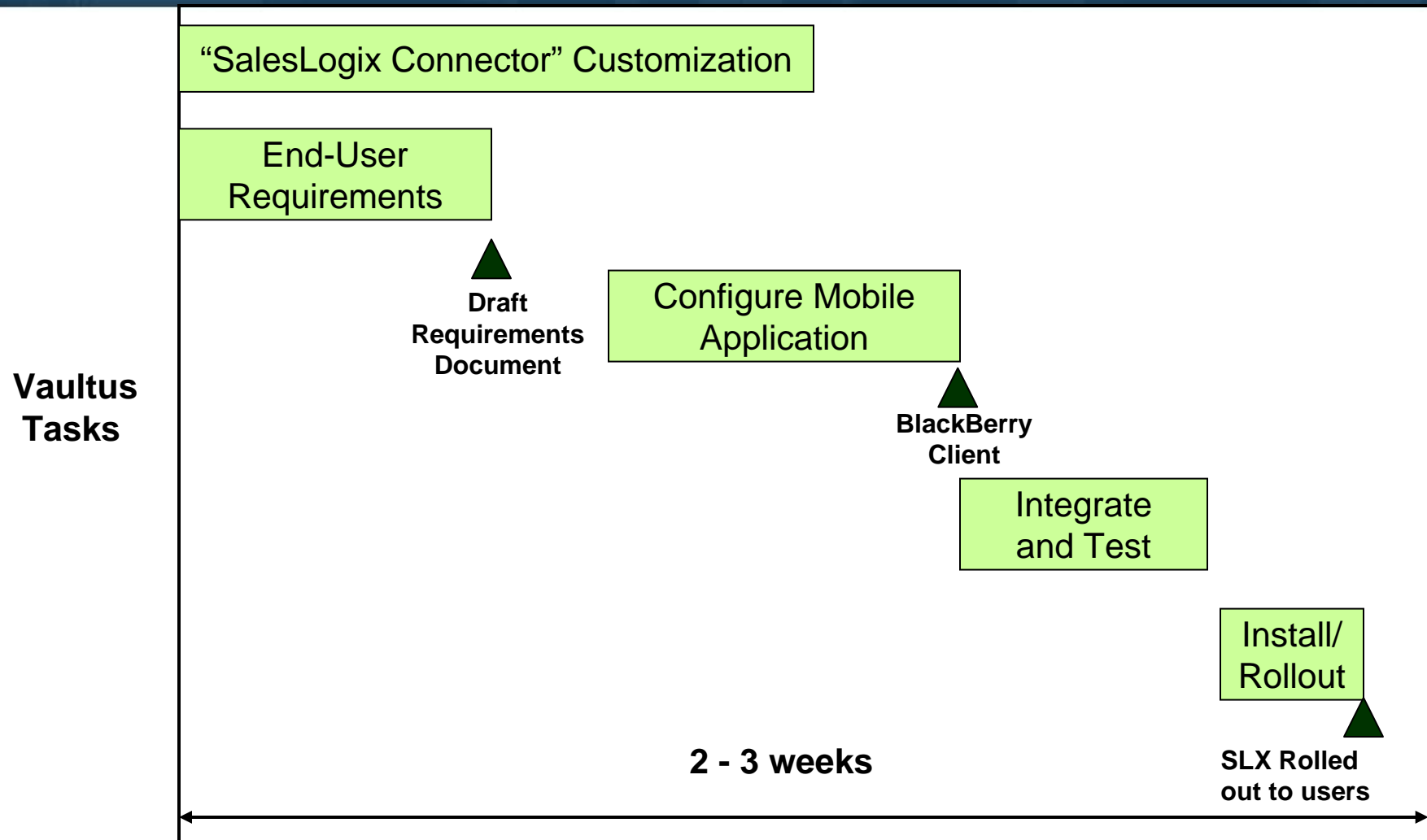

**For More Information**

**Vaultus Mobile Technologies**

**[www.vaultus.com](http://www.vaultus.com)**

**QISYS SalesLogix**

**<http://saleslogix.qisys.com>**



# BlackBerry Enterprise Resource Center

- **Last week's SalesLogix webcast**
- **All other webcasts**
- **White papers**
- **Case studies**
- **Reference documents**
- **Information by: platform, vertical market, deployment stage**

<http://resourcecenter.blackberry.com/>

**This concludes today's webcast...**

# **Webcast Q&A**

**For more information, to view live or on-demand webcasts or to download whitepapers and reference docs, please visit:**

**<http://saleslogix.qisys.com>**

